

VISUAL TELLING
FOR A *BIBLIA PAUPERUM*
IMMERSIVE
NARRATIVITY
IN THE CHAPEL VIII
AT SACRO MONTE
IN VARESE

Maria Pompeiana Iarossi¹, Giacomo Gramegna¹, Cecilia Santacroce¹

¹Politecnico di Milano

Department of Architecture, Built environment and Construction engineering

mariapompeiana.iarossi@polimi.it

ESSAY 115/07

SACRO MONTE IN VARESE
QUADRATURISM
17TH CENTURY ART
CULTURAL HERITAGE
VISUAL COMMUNICATION

Located along the slopes of the north-western pre-Alpine arc, the Sacrimonti, erected between the end of the 15th and the beginning of the 18th century in the Piedmont and Lombardy areas, represent not only an important historical and artistic contribution to the Unesco World Heritage, but also some examples of real experiential, immersive and inclusive paths, designed to reach even the least literate users with a powerful didactic and catechetical message, without the need for any textual integration. The paper analyz-

es the architectural structure of the chapel VIII, *L'Incoronazione di Spine* [The Crowning with Thorns], and its interaction both with the total structure of the monumental path designed in 1604 by Bernascone on Monte Velate of Varese and with the sculptural group and the cycle of frescoes, revealing its nature as a real storyboard, aimed at narrating one of the most dramatic episodes of the Jesus' passion and at raising an empathic relationship with the faithful who observe the setting through the external openings.

INTRODUCTION

Located along the slopes of the north-western pre-Alpine arc, the Sacrimonti, erected between the end of the 15th and the beginning of the 18th century in the Piedmont and Lombardy areas, together they constitute, not only an important historical and artistic contribution to the World Heritage Sites recognized by UNESCO for nine of them, an extraordinary testimony of the semantic power and didactic capacity that can be deployed with the sole use of visual communication. In fact, these monumental complexes show how landscape design, architecture, scenography composition, sculpture and painting can contribute to preparing what in today's language we would define as real experiential, immersive and inclusive paths, intended to reach even the least literate audience with a powerful message of a didactic and catechetical nature. In the spirit of the Counter-Reformation, a *Biblia pauperum* is therefore elaborated and effectively tested in the Sacrimonti, as an entirely iconological communicative model that, without any need for textual support, it is proposed as the Catholic answer to the claim of inclusiveness inherent in the German translation and Bible printed publication, which had supported and nourished the spread of Lutheran and Calvinist Protestantism in the lands beyond the Alps and in the Alpine valleys (Figure 1). This purpose is pursued through an operation of designing places that have very often been object of cult and popular devotion for centuries.

In 1565, just two years after the end of the Council of Trent, Galeazzo Alessi was commissioned to design the extension and transformation of a 15th century devotional path, which had been built in Varallo by the Franciscan friar Bernardino Caimi and the Valsesian architect Gaudenzio Ferrari, with the initial aim of proposing a substitute destination for the pilgrimage to the Holy Land, in the face of the unexpected conditions of insecurity in the Mediterranean, now controlled by the Ottoman fleet and infested by Barbary pirates (Scotti, 2012). The articulation of the Varallo complex along a steep slope and

the consequent fatigue of the visitor in walking along it would have constituted, for the purpose of obtaining indulgences, the seal of its effectiveness as a replacement for the pilgrimage to Jerusalem. The Alessi project sets off the end of this original topopoietic and topomimetic will of generate a 'elsewhere space' in the Sacro Monte, to transform it into a teaching and catechizing device at the service of Counter-Reformation orthodoxy, able to inculcate the Catholic faith's principles and dogmas even in the humblest classes (Quercioli, 2005).

In 1584, the year of his death, the Milan bishop Cardinal Carlo Borromeo, a prominent figure in the Counter-Reformation, visited Varallo and decided to place its construction under the direct control of the episcopal authority, together with the centralized management of devotional places in the Lombard-Piedmonts area. This control will then pass into the hands of

Fig. 1 In the spirit of the Counter Reformation, the architectural complex of Sacro Monte represents an entirely iconological communicative model of catechetical contents.

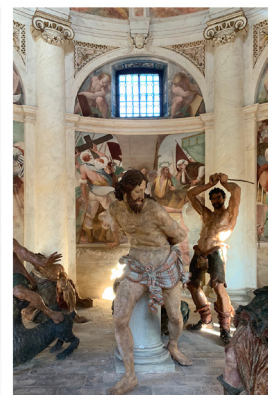

the bishop of Novara Carlo Bascapè, who will leave an even more unified imprint on the spatial reorganization and on the ways of using all the devotional paths, starting from the Varallo paradigm, albeit appropriately revised and modified. For example, the exclusion of pilgrims from entering the chapels and the obligation to observe the interior only from specific points of view, corresponding to gratings and windows, is attributable to the prescriptions of the Bascapè (Scotti, 2012), an obligation that transforms the interior into real theatrical sets, whose use is entirely governed by the laws of perspective vision. From the point of view of the narrative contents, however, the *Libro dei Misteri* [Book of Mysteries], which collects the *corpus* of Alessian drawings referring to the project for Varallo (Alessi, 1974; Balestreri, 2012), already expresses in the title the desire to translate into a precise architectural articulation the prescriptions issued for the recitation of the Rosary by Sisto V with the papal bull of 1571. Due to this adherence to the papal dictate, this book ends up affirming itself as a real reference handbook for the realization of the next Sacrimonti –Crea

Fig. 2 Front view of chapels and the devotional path with the main altitude value.

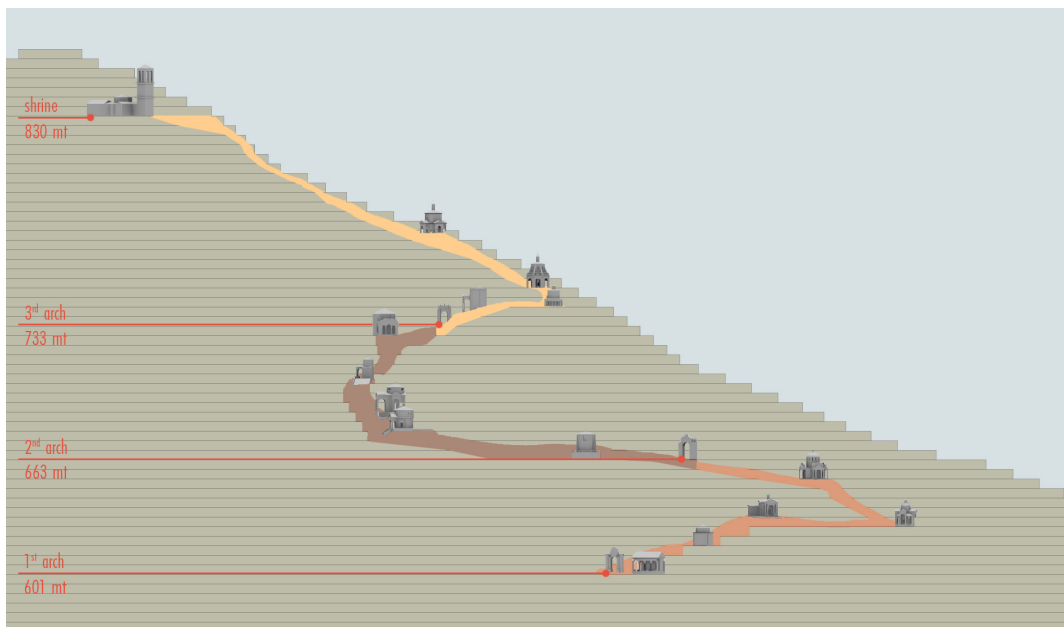

(1589), Orta (1591), Varese (1614), Oropa (1620), Ossuccio (1635), Ghiffa (1647), Domodossola (1657) and Belmonte (1712)– although only two of them, Ossuccio and Varese, are punctually referred to the Rosary Mysteries.

In fact, it is precisely the episodes of the life, passion, death and resurrection of Jesus, as evoked in each of the 15 Rosary Mysteries –tripartite in Joyful, Painful and Glorious Mysteries– that constitute the theme of each 14 chapels in which the path of the Sacrimonti is articulated, until reaching a sanctuary on the top, generally dedicated to the Assumption of the Madonna, an event evoked in the fifteenth mystery, the one with which the recitation of the Rosary ends (Figure 2).

PECULIAR CHARACTERISTICS OF THE SACRO MONTE IN VARESE

The narrative organization codified by Alessi with the explicit reference to the Rosary Mysteries finds in Varese a particularly faithful declination to the dictates of Pope Sisto V's bull and the whole monumental itinerary's architectural articulation appears as an accurate transcription of this prayer in forms and images, produced as magnificent theatrical staging, thanks to the collaboration of the architects, sculptors and painters' skills, further enhanced by the specific landscape location of the complex. In Varese, the Sacrimonti typical urban and scenic component finds its most complete expression, since the relationship with the surrounding nature determines its dimensional expansion, while its location on Monte Velate, higher than the city, favors its observation from all the surrounding places (Langé, 1967). It is an arduous area, but object of devotion and pilgrimage since the 4th century, as it had been the scenario of a battle that had seen the Arians defeat by the bishop of Milan Sant'Ambrogio, who erected there, according to the legend, an altar consecrated to the Madonna della Vittoria, to thank her for the victory, which soon became the destination of pilgrimage for centuries.

Like in Varallo, in fact, also the Sacro Monte of Varese is the result of a series of successive interventions which, taken together, seem to reveal a tendency to the permanence of the sacred places. In 1474, Pope Sisto IV granted Giuliana Purricelli and Caterina da Pallanza to establish the Romite Ambrosiane Monastery on Monte Velate, near which a couple of chapels were then built, with statues and frescoes depicting three moments of the Passion and a sanctuary (Bertoni, 1992). The latter, following a significant expansion carried out already at the end of the 15th century assumed the structure of a building with three naves with a presbytery with three apses, enriched along the time by altars with statues and the construction of further adjacent buildings of worship (Bertoni, 1992; Rinaldi, 1992). The continuous presence through time of these buildings and artefacts seems to suggest the precocious presence of a sort of Sacro Monte *in nuce*, consisting of some votive shrines, object of worship and manifestations of popular religiosity, a circumstance already described with reference to Varallo, but also found in Ossuccio, in Oropa and in most of the Sacrimonti.

But, even within this place's sacred vocation continuity, the choice to build a devotional path, mainly conceived as a religious training tool, marks a discontinuity and a so clear desire of change, such that it requires the drafting of an overall project, capable of making cooperating, in view of the new purpose, the many artisanal and artistic skills necessary for its realization. It is therefore with this spirit that, at the end of the 16th century, the Capuchin father Giovanni Battista Aguggiari, spiritual guide of the Order of the Ambrosian Romite, commissioned the architect Giuseppe Bernascone to create a path of access to the sanctuary flanked by chapels (Quercioli, 2005). Bernascone designed the entire complex—whose construction began in 1604 and was concluded only in 1717—regulating the relationship of the path with the surrounding nature and with the individual aedicules' architecture by scanning the path into three parts, corresponding to the three groups of Mysteries of the Rosary, each preceded by a monumental arch. The path takes on the structure of a real avenue, which climbs from

an altitude of about 600 meters above sea level of the entrance up to 830 meters of the sanctuary, alternating protective stone parapets of the steep slope below with fountains, porticoed pitches and panoramic terraces, often placed as a mediation between the avenue and the external pronaos or ambulatory of the single chapel (Figure 3).

From the *Ragguaglio* of 1623, preserved in the archiepiscopal archive of Milan (Lutze, 1992), it is clear that on that date the wall structures of all the chapels were finished, except the fifth and the three triumphal doors, while the twelfth chapel and the three fountains used for the refreshment of pilgrims had not yet begun (Lutze, 1992). It is not clear that these last artifacts are entirely attributable to Bernascone, who died during the plague epidemic of 1630-1632. However, there is no doubt that he was able to give the entire Varese complex

Fig. 3 Abacus of chapels and arches composing the Sacro Monte.

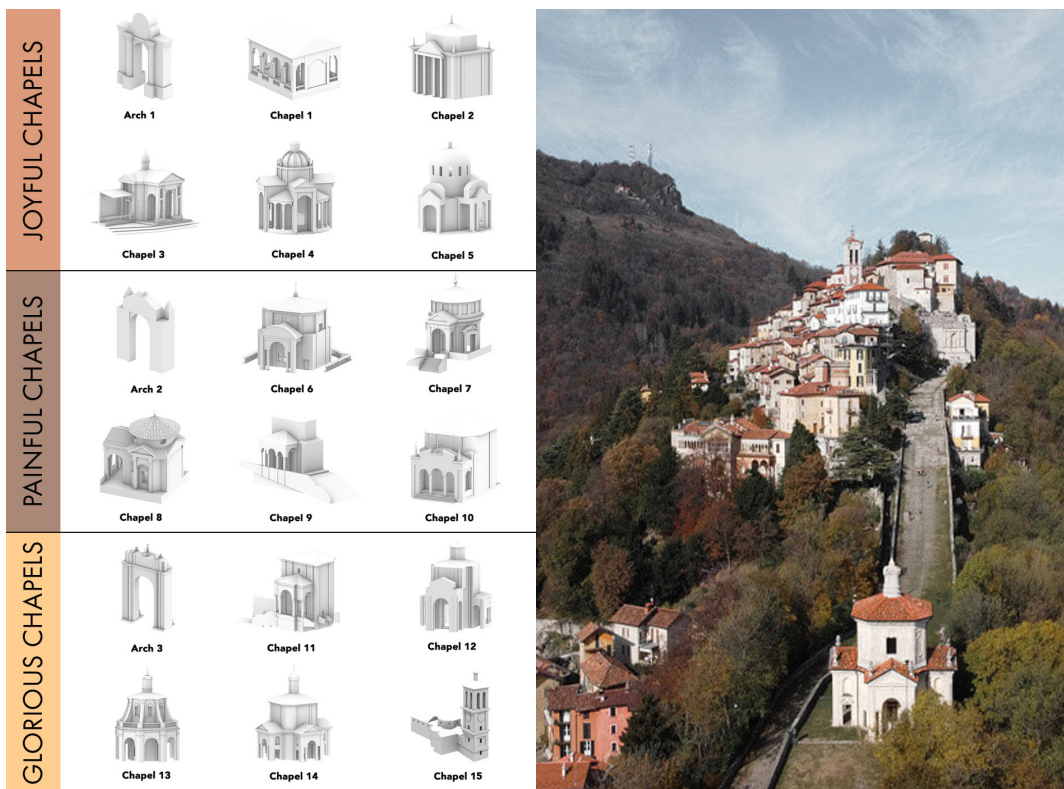

a strongly unitary imprint, recognizable even in the creations certainly implemented after his death, such as, for example, the plastic and pictorial decorations inside the chapels, in most cases datable around 1640 (Bianconi et al., 1981). With particular reference to the internal frescoes, there is a substantial difference between them and their similar constructions in the other contemporary Sacrimonti's chapels, where they are declined as simple backdrops to the sculptural compositions. In this sense, the frescoes perform a scenography function not devoid of a certain figurative conventionality, which seems to refer to the Serlian classification of tragic, comic and satirical theatrical scenes (Iarossi, 2016) or, they introduce some specific buildings as a key to reading the catechetical message of the chapel, as in chapel II, *La Visitazione* [The Visit] in Ossuccio with the representation of the cross vault of the Filaretian hospital, as an emblem of the welcome given to the pilgrim (Iarossi & Santacroce, 2021).

In general, in these frescoes the human presences are very scarce and, even when they appear, they are nothing more than simple extras with almost only ornamental value. In Varese, instead, the wall frescoes cannot be considered simply backgrounds of the statuary groups, but they constitute real autonomous pictorial compositions, crowded with characters and as more analytically described later, they interact with the typological characters and the architectural language of the building in which they are located, building a real storyboard of the evangelical event to which each chapel is dedicated.

ARCHITECTURAL-TYOLOGICAL CHARACTERISTICS OF THE CHAPELS AND THE ARCHITECTURE OF THE CROWING CHAPEL

Chapel VIII belongs to the group of Painful Mysteries, located in the north-west area, the most inaccessible and arid of the mountain (Langé, 1967). After the Second Arch, called Porta di San Carlo and flanked by a fountain, proceed towards

the chapel VI, *Orazione nel Getsemani* [Orison in Gethsemane], and after a sharp bend, the path becomes straight and the narration tight, with the chapels: VII, *La Flagellazione* [The Whipping], VIII, *L'Incoronazione di Spine* [The Crowning with Thorns], IX, *La Salita al Calvario* [The Ascent to the Calvary] and X, *La Crocifissione* [The Crucifixion]. The avenue adapts itself both to the surrounding nature and to the story told inside the aedicule, visually connecting the chapels to each other. The pilgrim, therefore, in addition to having an overall vision of the Painful Mysteries, from this section also sees Monte Tre Croci and the Sanctuary of Santa Maria del Monte, the destination of his journey as well as a symbol of salvation and ascension. With the Third Arch, the Porta di Sant'Ambrogio, the portion of the Painful Mysteries ends, and it proceeds towards the Glorious ones, which constitute the final stretch of the devotional path (Figure 4).

Fig. 4 Digital model of the path's portion corresponding to the painful mysteries, elaborated on the basis of the DTM-Digital Terrain Model of the Lombardy Region, with the position of the relative chapels. Retrieved June 16, 2020 from <https://www.geoportale.regione.lombardia.it/servizi>

From the typological point of view, all the aedicules are with a central plan, developed in different variants, from the simple circular body preceded by a pronaos to the circular or octagonal plan with ambulacrum. However, there are also

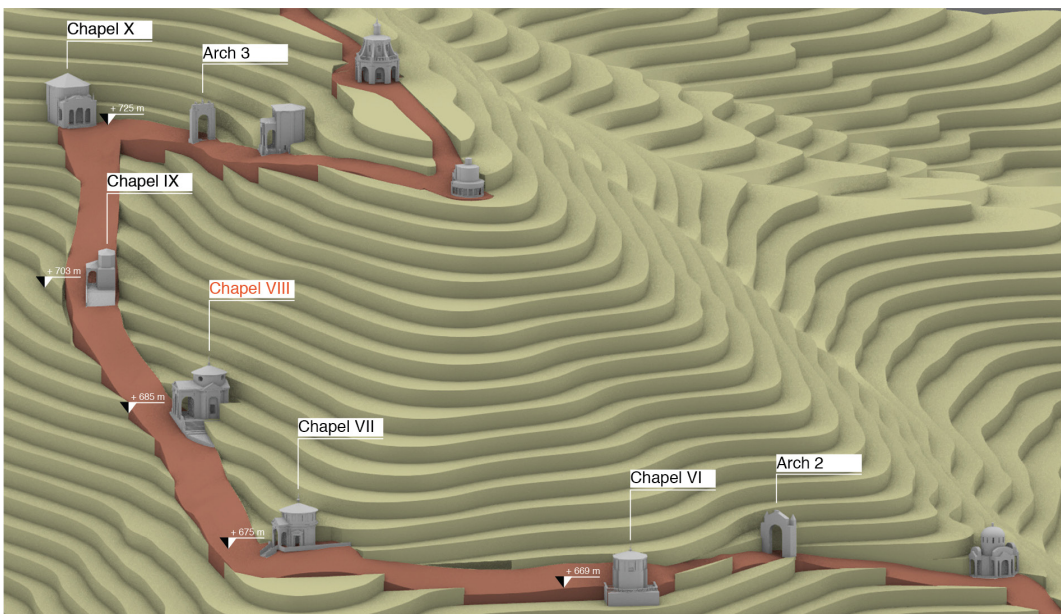

Fig. 5 Chapel VIII, photographs of the relationship with the path.



hall-shaped chapels, with a square or rectangular plan, often surmounted by elliptical roofs (Langé, 1967). As Squizzato (2004) points out, their structure often takes into account the proposed Mystery and the position of the artefact, favoring more complex solutions for the most salient events, such as for the chapel V, *La Disputa nel Tempio* [The Debate in the Temple] and, precisely, the VIII, *L'incoronazione di Spine*.

This chapel stands on a podium that absorbs a difference in height equal to 2 meters and can be reached via a large staircase located to the south, with the ascent direction parallel to the avenue, while to the north the pronaos connects through a short ramp of modest slope to the path main, which continues towards the next chapel (Figure 5).

The pronaos is bordered by a balustrade and articulated by round arches and Tuscan pillars, surmounted by a massive pediment. On the counter-façade there are the three windows and a small half-hidden door, used for access by maintenance staff only. Externally, three main volumes can be defined: the massive pronaos in front of the west elevation, the octagonal prism corresponding to the main body of the chapel and the cylindrical tambour surmounted by a rather flattened conical roof containing a hemispherical dome (Figure 6).

The central octagonal plan establishes a dualism between exterior and interior, since the volume described differs from the internal one: the cylindrical lantern without moldings, in which there are four oculi that illuminate the interior, conceals a cover composed by a vaulted ceiling pavilion set on an octagonal base. The peculiarity of this chapel is also revealed in

Fig. 6 Chapel VIII, main elevation and cross section (above), plan (below).

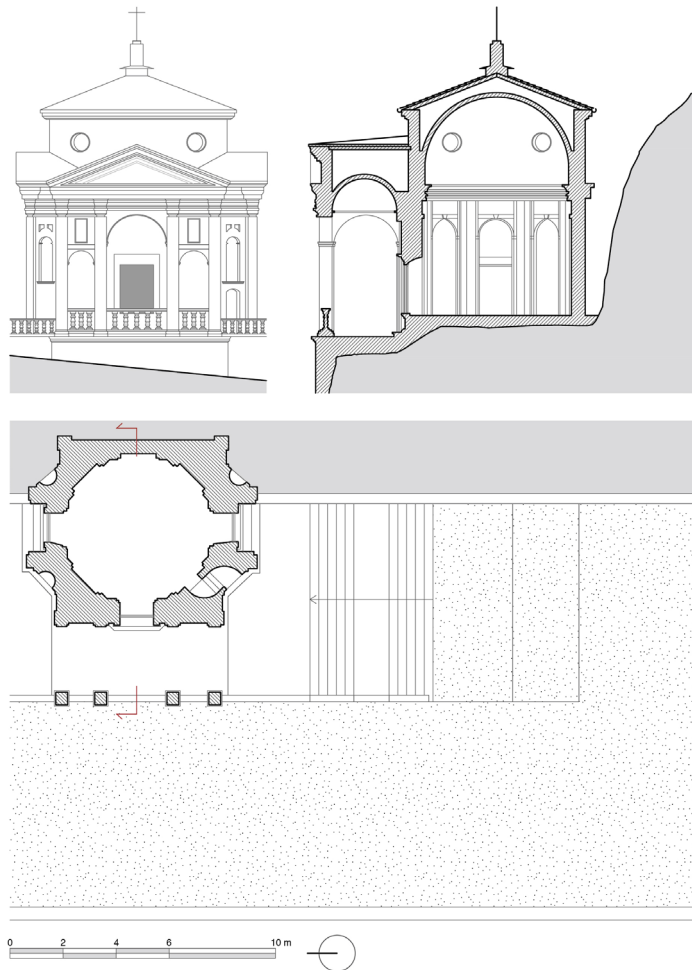

the presence of the three windows placed on three different façades, while on the other hand, in the other Sacrimonti the openings, when there are more than one, are all located on the main facade, determining almost frontal points of view.

Instead, Bernascone's project had already arranged three different points of view for chapel VIII, from which it is possible to observe the interior set up at an elevation of three steps above that of the pronaos. While the side openings are framed by a porch with lateral Tuscan pilasters, the main opening, also glazed and with the presence of decorated gratings on the outside and a kneeler, represents the main and frontal point

of view to the scene, emphasized at a geometric level by the presence of the dome in the pronaos' roof which in a central plan scheme could define a main axis (Figure 7).

From these three windows the scene is visible, consisting of a group of ten terracotta statues made by Francesco Silva (Quercioli, 2005), while on the walls and in the dome, there are painted squares that evoke scenes and spaces with different articulations from the physical space of the chapel. The chapels' interior, as result of the integration of sculptural, pictorial and scenography art, present a certain linguistic and stylistic homogeneity between them. After all, as a result of the realization of all the Sacrimonti within a rather limited time, specialized workers have come to train, moving from one Sacromonte to another, often belonging to the same family of painters or modelers (Gatta Papavassiliou, 2013) –like the Silva family, the Prestinaris and the Rezos– helping to create a quite common style and a language. In particular, the sculptors specialize in the creation of hollow terracotta sculptures –thanks to the use of the wax technique– about one third larger than the reality (Lotti, 1992) and with an accentuation of the expressive characters with the aim to characterize and make contrast between good and bad. The colors used are often of the same shades used also in the frescoes on the walls so as to give unity to the various scenes, performed by painters of the Lombard school such as Nuvolone, Morazzone and Recchi.

THE INTERIOR LAYOUT OF CHAPEL VIII AND ITS NARRATIVE CHARACTER

The iconographic program of chapel VIII is based on the theme of *L'incoronazione di Spine*, which is part of one of the five sorrowful *Mysteries* of the Rosary. The construction of the interior set-up takes place temporally after the interruption due to the plague epidemic of 1630, as evidenced by a plaque painted inside, which shows 1648 as the year of execution of the frescoes by the brothers Giovan Battista and

Fig. 7 Chapel VIII, axonometric view.

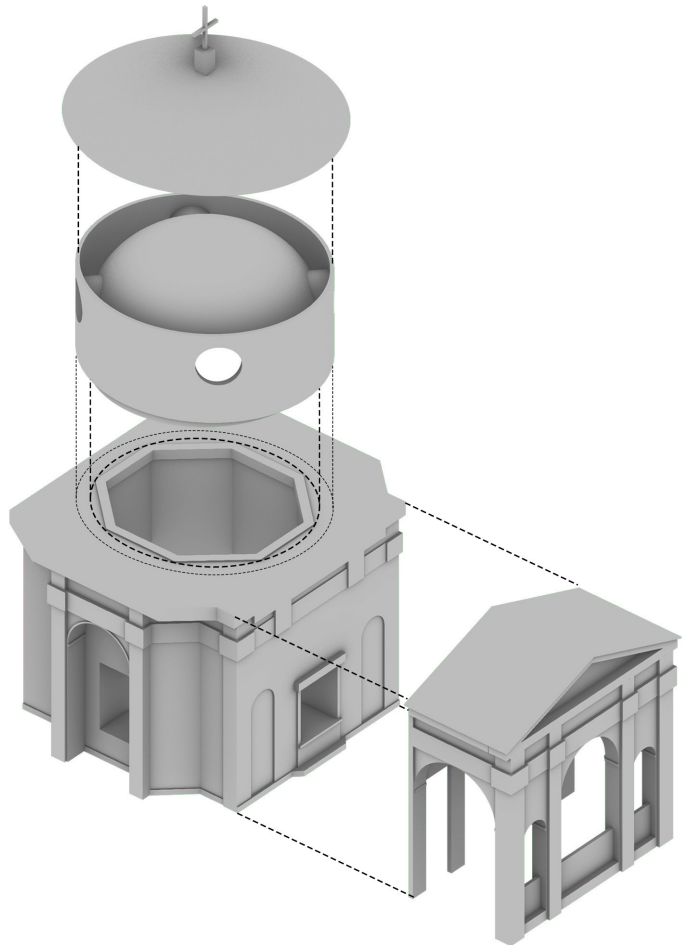

Giovan Paolo Recchi¹. The entire decorative system is the result of an accentuated interaction between figurative art, sculptural and architectural art, which in this chapel gave rise to a strongly coherent narration, creating a particularly engaging scenic effect, starting with the sculptural group by Francesco Silva who stages the crowning with thorns, continuing with the squares present on each of the eight vertical walls of the chapel. Here are reported episodes taken from the Gospels and related to the condemnation of Christ and his thorns coronation. The hemispherical dome is grafted on the upper surface, on whose internal surface, through a skill-

ful perspective composition, an octagonal umbrella vault is simulated (Iarossi, 2016), surrounded by a lantern with a balustrade from which eight characters appear intent on looking at the scene below (Figure 8). Unlike the other Sacramonti, where the pictorial wall decoration is aimed only at simulating different spaces than the chapel's physical one, in all the chapels of the Sacro Monte in Varese it has the role of narrating the episode inherent in each chapel through images, according to narrative methods similar to those that today could be used for the arrangement of the storyboard for a short film, articulated in the 8 perspective squares and culminating in the scene represented by the sculptural group that dominates the central area of the chapel. In particular, in chapel VIII, *L'incoronazione di Spine*, in the wall frescoes there are a large number of characters who interact with the architectural structure of the chapel, suggesting that these frescoes were painted in support of a narrative that entrusts the task of telling the story not only to the sculptures, but also to the painted images and their scenography composition.

If we compare these wall paintings with those of the corresponding eighth chapel in Ossuccio, it can be seen that only 19 characters are portrayed in the latter, while in that of Varese there are a total of 82, of which 57 in the quadratures, 8 couples of angels in the rectangular frames above each quadra-

Fig. 8 Chapel VIII, frescoes and sculptural group.



ture, to support the cartouches containing verses from the Psalms², and finally the 9 characters portrayed as if looking out from a balcony under the dome. With reference to the catechetical role of the Sacrimonti, compositional analogies can be detected between the eight squares present on the walls and the practice of narrating through the sequential juxtaposition of small scenic spaces typical of medieval theater³. The study was conducted through the reconstruction of the storyboard as a scenic and temporal sequence of the frescoes, analyzed in relation to the interaction of the frescoes with the chapel's architectural articulation and with the morphology of the entire devotional path. A previous study (Corsini, 2000) formulated an interpretation of the reading sequence of the eight squares, highlighting how the Recchis brothers interpreted and represented scenes taken from all four Gospels together, without adhering to a specific one. This is observed in particular for those scenes that narrate the processes to which Christ is subjected –before Caiaphas, Pilato and Herod Antipas– which are extrapolated above all from the Luke's Gospel, while the scenes representing the preparation of the crown and the coronation, are more faithful to what is described in the Gospels of Matthew and Mark.

Thanks to the presence of the scrolls with extracts of the Psalms⁴ frescoed above each quadrature and the iconographic similarities found with the previous chapel frescoed by Morazzone, teacher of the Recchis brothers, it is possible to identify the subject of each quadrature. The frescoed episodes appear to be the crowing with thorns, Christ in front of Caiaphas⁵, Christ in front of Pilato, request of crucifixion⁶, Christ in front of Herod Antipas⁷, Pilato washes his hands, undressed Christ and preparation of the thorns' crown. According to Corsini's interpretation, the initial scene of the sequence would appear to be the one placed on the main axis of the chapel, directly behind the statues, depicting the character of Caiaphas (A), also present in chapel VII, *La flagellazione*, frescoed by Morazzone, in the act of judging Christ⁸. Again, according to the Corsini hypothesis, one would con-

tinue to the right and the second scene would refer to the first interrogation of Pilato (B)⁹, character depicted in the lunette above the window with the kneeler, and then continue with the invocation of the crucifixion (C) by the chief priests and the crowd¹⁰ and the sending of Christ to the governor of Galilee Herod Antipa (D)¹¹, to be recognized by him as guilty. Although the fresco here is very damaged, it is certain that the scene depicts this particular episode due to the garments worn by Christ, quoted from the excerpt of Psalm 68 shown above the scene that evokes the verses of Luke¹². Once interrogated by Herod, Christ is sent back to Pilate who, having failed to save Jesus for the third time, washes his hands (E) and leaves him to the judgment of the crowd and the chief priests. From here on, the narration becomes more rapid and hard, with the undressing of Christ and the laying of the purple mantle of kings (F)¹³, the preparation of the thorns' crown (G)¹⁴, the crowing (H)¹⁵. The storyboard ends with the scene set up three-dimensionally with the statues, in which with a high level of drama, the crowd and the soldiers beat and mock a suffering Christ, crowned with thorns and ready to be taken to Calvary.

This reading, closely linked to the chronological succession of the events described in the Gospels, is however not very convincing, assuming that the preferential point of view is placed inside the chapel and that the sequence takes place in a clockwise direction, starting from the fresco placed behind the sculptural composition. However, this interpretation does not take into account either the impositions of Bishop Bascapè regarding the methods of using the devotional paths and the prohibition of access inside the shrines or the architectural features of the chapel itself which, as mentioned above, it has three windows from which the pilgrim could only look inside from the outside. In fact, if we consider the three windows as standing points from which to observe the interior of the chapel, Corsini's interpretation would imply that the visitor would first stop in front of the central window the kneeler (2), the one on the

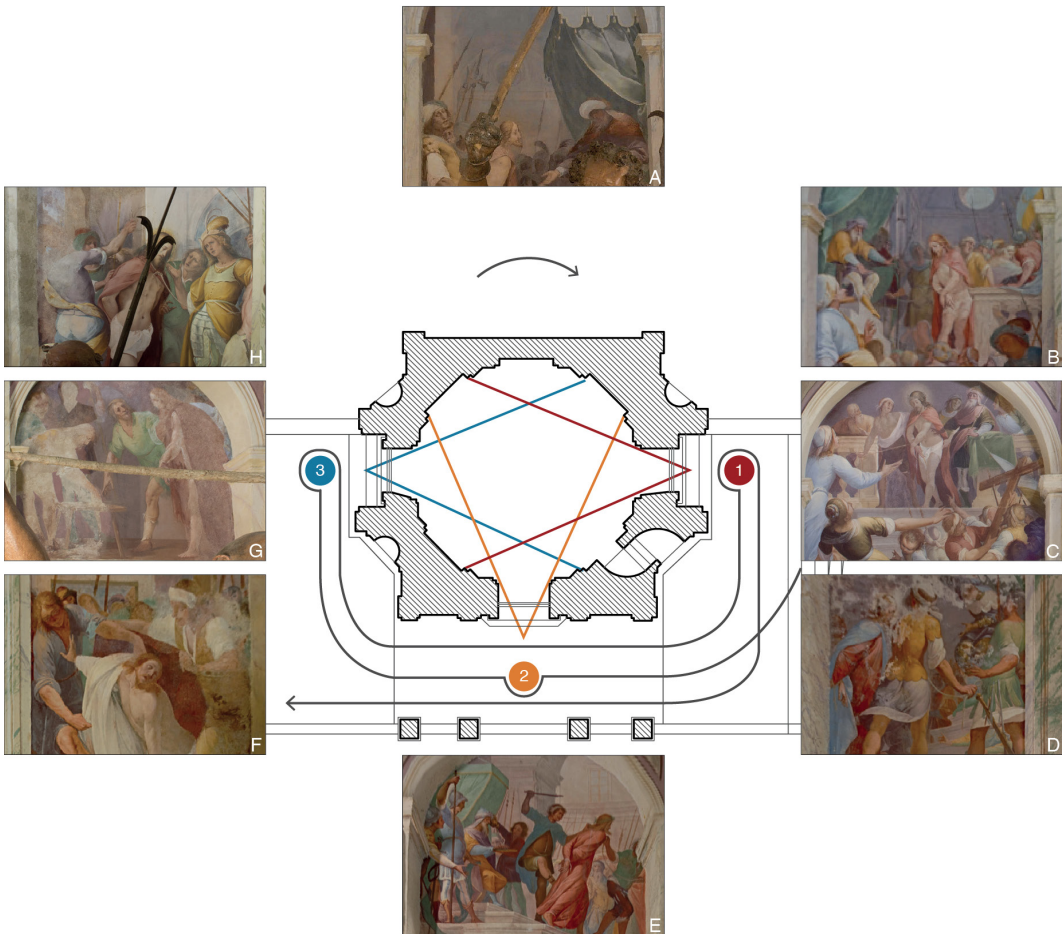

Fig. 9 Corsini's hypothesis of the path for contemplation of the internal set-up.

left facing the next chapel IX (3), to finally return to the one on the right downstream (1), which corresponds to the one placed immediately in front of the staircase from which it arrived coming from the chapel VII. Therefore, again according to the Corsini's reading, the observant should at this point come back to his steps and walk again under the chapel's pronaos, and then continue the devotional path up to the next chapel (Figure 9). In addition to the obvious irrationality chapel's use path presupposed by the interpretation already proposed, it fails to consider the close interrelation between architecture, painting and sculpture in the catechetical nar-

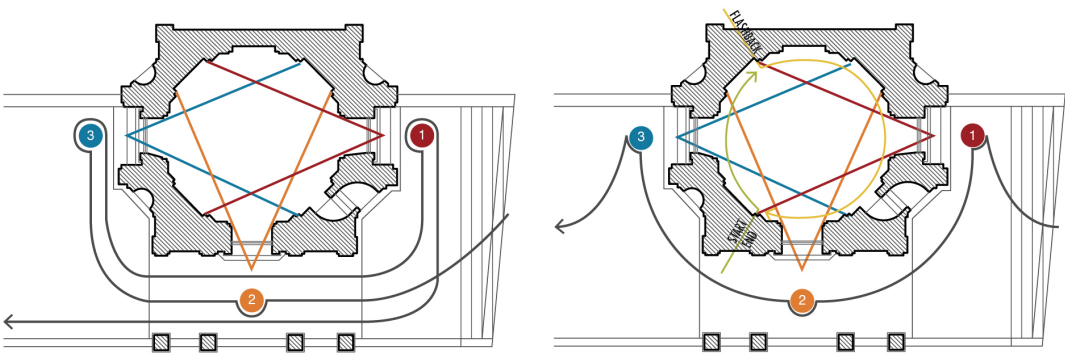

Fig. 10 Comparison between Corsini's hypothesis and the one referred to the architecture of the chapel.

ration of the Sacrimonti's chapels in general and the relation between them and the itinerary of the observants who go through the entire devotional complex. Indeed, the VIII chapel, placed parallel to the devotional path in continuous ascent, is accessed through a long staircase which, arriving at the first window on the right, leads to the pronaos on which the main window opens with the kneeler, to continue then to the third window on the left and, from here, reconnect to the path towards the next stage through the small connecting ramp (Figure 10). However, this sequence of use, imposed by the typological structure of the chapel, requires that the sequence of the preferred observation points for the internal set-up starts from the right window –the one that the visitor is in front of after having climbed the staircase– continues stopping in front of that center one with the kneeler and, finally, move in front of the left window upstream, from which the visitor can then descend through the ramp and go to the next chapel (Figure 11).

This requires a different interpretation of the storyboard, which would include the beginning of the sequence with the rapid succession of frescoed scenes regarding the undressing, the preparation of the crown and the coronation, in a dynamic and dramatic crescendo, which finds its full conclusion in the action described by the sculptural group (I) visible from the central window with the kneeler, and emphasized by the presence in the frescoed dome of the medallion showing the Isaac's sacrifice and the woman pointing to the scene

Fig. 11 Preferred points of view's sequence from which to look at the interior of the chapel, corresponding to the window on the right (1), the central one with the kneeler under the pronaos (2) and the one on the left (3).

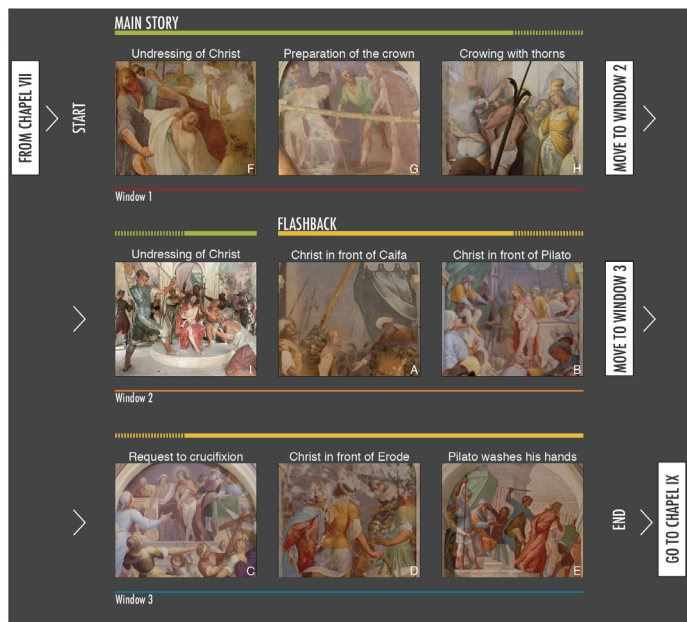
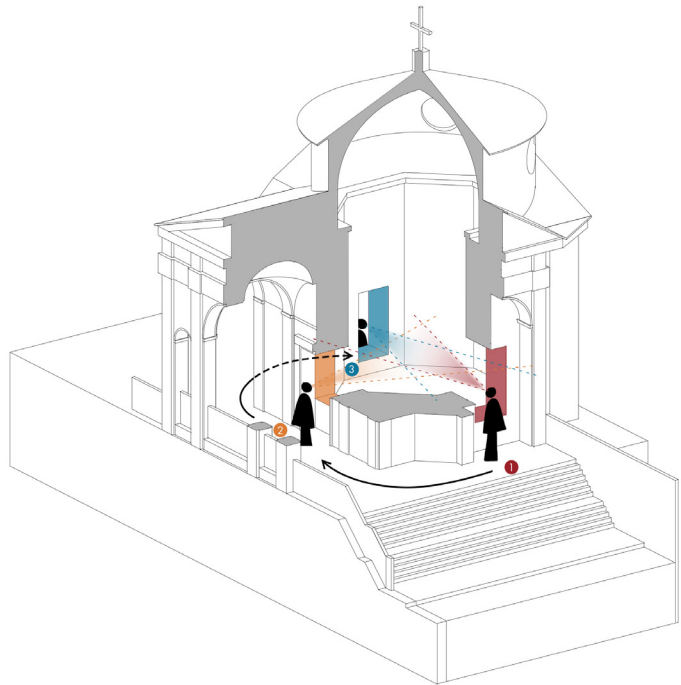

Fig. 12 Reading of the storyboard composed by the chapel's frescos, highlighting the use of flashback technique.

below. Finally, in the continuation of the devotional path, from the same standing point of the central window and from the third point of the left window, the user can watch the scenes that narrate the causes that led to the coronation of Christ, as it happens in a cinematic flashback that unfolds the events that have previously occurred and which turn out to be the key to deciphering the dramatic events theatrically staged (Figure 12).

CONCLUSIONS

The presented reading of the frescoes, subordinated to the chapel's use, is therefore revealed as a dramatic, exclusively iconographic narration of the story of the God's Son and the process that leads to his crucifixion, told with acceleration of the story and even with the recourse to the flashback technique, with the aim of supporting the catechetical message, stimulating Christian adherence to Christ's pain through the empathic involvement of even non-cultured visitors as well.

ACKNOWLEDGEMENTS

Although the paper is the result of the collaboration of the three authors, the following attributions can be distinguished: *Introduction and Peculiar characteristics of the Sacro Monte in Varese* by Maria Pompeiana Iarossi, *Architectural-typological characteristics of the chapels and the architecture of the Crowing chapel* by Giacomo Gramegna, *The interior layout of chapel VIII and its narrative character* by Cecilia Santacroce. The remaining parts are drafted in common.

NOTES

1 The plaque, placed on the left pilaster of the access door to the chapel, reports the following wording: "IO BAPTISTA ET IO PAVLVS FRATRES DE RECHIS COMENSES P. ANNO 1648".

2 In particular, reference is made to the Psalm of David, king of Israel, from which Joseph, the father of Jesus, descends.

- 3** We refer to the typical set-up *à maison* of the cycles of *Mystères de la Passion*.
- 4** The state of conservation of the frescoes does not allow the correct reading of the Psalms. Despite this, of those that present a good state of conservation, it was possible to understand that they were extracted from Psalms 22 (Psalm of the suffering servant) and 68 (Psalm of lament).
- 5** Here is Psalm 22, 8: *Omnes vedentes me deriserunt me, torquentes labia moverunt caput* [Those who see me mock me, twist their lips, shake their heads]. Reference is made to the mockery and blows that the Sanhedrin and the guards perpetuate against Christ.
- 6** Here is Psalm 22, 7: *Ego autem sum vermis, et non homo: opprobrium hominum, et abjectio plebis* [But I am a worm, and not a man: the opprobrium of men, and the rejection of the plebs].
- 7** Here is Psalm 68, 12: *Et posui vestimentum meum cilicium et factus sum illis in parabolam* [I wore a sack as a dress and became an object of ridicule to them]. The reference is to the Luke Gospel 23,11 in which Herod, before sending Christ back to Pilate, dresses him with a splendid mantle.
- 8** Mt 26, 57; Mk 14, 53; Jn 18, 13.
- 9** Mt 27, 11; Mk 15, 2; Lk 23, 3; Jn 18, 33.
- 10** Mt 27, 11; Mk 15, 2; Lk 23, 3; Jn 18, 33.
- 11** Lk 23, 6-7. Only in the Gospel of Luke is there a reference to this particular episode. Pilato, once he knew that Jesus is a Galilean, therefore of the jurisdiction of Herod, sent him to him, who was in Jerusalem in those days.
- 12** As we read in Lk 23:11, Herod dresses Jesus in a splendid mantle before sending him back to Pilato.
- 13** Mt 27, 28; Mk 15, 17; Lk 23,11; Jn 19,2.
- 14** Mt 27, 28; Mk 15, 17; Jn 19, 2.
- 15** Mt 27, 28; Mk 15, 17; Jn 19, 2.

REFERENCES

- Alessi, G. (1974). *Libro dei misteri: progetto di pianificazione urbanistica, architettonica e figurativa del Sacro Monte di Varallo in Valsesia (1565-1569)* (Rist. anast. ed.). Sala Bolognese, IT: Arnaldo Forni.
- Balestreri, I. (2012). L'architettura del Sacro Monte di Varallo. Disegni, progetti, vedute fra XVI e XVII secolo. Una proposta di lettura. In I. Balestreri & M. Meriggi (Eds.), *L'architettura del Sacro Monte. Storia e progetto* (pp. 9-23). Milano, IT: Libraccio.
- Bertoni, A. (1992). La Basilica di Santa Maria del Monte sopra Varese: religiosità, arte e committenza tra quindicesimo e sedicesimo secolo. In L. Vaccaro & F. Ricardi (Eds.), *Sacri Monti: devozione, arte e cultura della Controriforma* (pp. 335-351). Milano, IT: JacaBook.
- Bianconi, P., Colombo, S., Lozito, A., & Zanzi, L. (1981). *Il Sacro Monte sopra Varese*. Milano, IT: Electa.
- Corsini, R. (2000). *Affreschi del Sacro Monte di Varese*. Gavirate, IT: Nicolini.
- Gatta Papavassiliou, P. (2013). *Il Sacro Monte di Ossuccio. Guida alle Cappelle*. Carlarzo, IT: Sampietro Editore

- Iarossi, M. P. (2016). Scenografie urbane e paesaggistiche nei fondali prospettici della cappella della Visitazione nel Sacro Monte di Ossuccio (CO). In G. M. Valenti (Eds.), *Prospettive architettoniche: conservazione digitale, divulgazione e studio* (Vol. 2) (pp. 189-205). Roma, IT: Sapienza Università editrice.
- Iarossi, M. P., & Santacroce, C. (2021). Costruzione dell'inganno architettonico. Due casi di proiezione prospettica su superficie cilindrica. In M. Rossi & M. Russo (Eds.), *L'eredità di Bramante, tra spazio virtuale e proto-design* (pp. 173-198). Milano, IT: FrancoAngeli.
- Langé, S. (1967). *Sacri Monti piemontesi e lombardi* (pp. 28-34). Milano, IT: Tamburini.
- Lotti, C.A. (1992). Note per una ipotesi sulla tecnica di esecuzione delle statue in cotto del Sacro Monte sopra Varese. In L. Vaccaro & F. Ricardi (Eds.), *Sacri Monti: devozione, arte e cultura della Controriforma* (pp. 321-325). Milano, IT: JacaBook.
- Lutze, S. (1992). L'architetto Bernascone ed il sacro Monte di Varese. In L. Vaccaro & F. Ricardi (Eds.), *Sacri Monti: devozione, arte e cultura della Controriforma* (pp. 315-320). Milano, IT: JacaBook.
- Quercioli, M. (2005). *I Sacri Monti*. Roma, IT: Istituto Poligrafico e Zecca dello Stato S.p.A.
- Rinaldi, L. (1992). Architetture religiose medioevali a S. Maria del Monte: recenti acquisizioni e scoperte. In L. Vaccaro & F. Ricardi (Eds.), *Sacri Monti: devozione, arte e cultura della Controriforma* (pp. 241-247). Milano, IT: JacaBook.
- Scotti, A. (2012). Paesaggi sacri tra Piemonte sabaudo e Lombardia borromaica: il contributo del Libro dei Misteri di Galeazzo Alessi. In I. Balestreri & M. Meriggi (Eds.), *L'architettura del Sacro Monte. Storia e progetto* (pp. 24-29). Milano, IT: Libraccio.
- Squizzato, A. (2004). *I Sacri Monti*. Bari, IT: Laterza.

Article available at

DOI: 10.6092/issn.2724-2463/15177

How to cite

as article

Iarossi, M. P., Gramegna, G., & Santacroce, C. (2022). Visual telling for a *Biblia pauperum*. Immersive narrativity in the chapel VIII at Sacro Monte in Varese. *img journal*, 7, 164-187.

as contribution in book

Iarossi, M. P., Gramegna, G., & Santacroce, C. (2022). Visual telling for a *Biblia pauperum*. Immersive narrativity in the chapel VIII at Sacro Monte in Varese. In A. Luigini, V. Menchetelli (Eds.), *img journal 07/2022 Wordless images* (pp. 164-187). Alghero, IT: Publica. ISBN 9788899586300



© 2022 The authors. The text of this work is licensed under a Creative Commons Attribution 4.0 International License.